

DRAINBOX



The details that make the difference...

Drainbox

SABdrain Drainbox has been developed to provide an inline pit along with the drainage system it has the advantages of increasing the head of water for outlet capacity while still providing aesthetics of linear design.

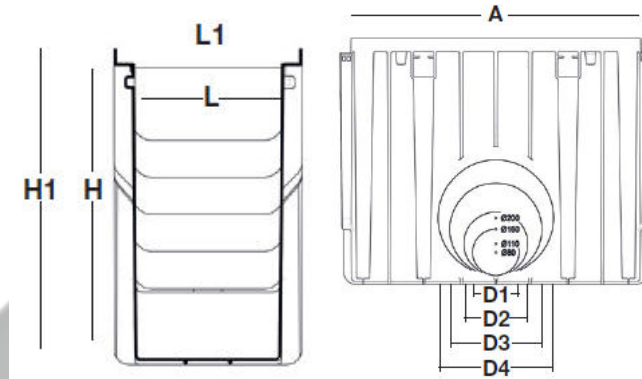

SABDRAIN DRAINBOX										
CODE	L	H	L1	H1	D1	D2	D3	D4	A	KG
DRBOX100	100	400	150	430	80	110	160	200	500	2.5
DRBOX150	150	400	200	430	80	110	160	200	500	2.6
DRBOX200	200	400	250	430	80	110	160	200	500	2.9

Compatible with 351, 501, 355, 356, 704, 705, 706, 707

