

Grate Tiles™

Installation

Jonite Grate Tiles™ are standard non-perforated solid slabs that have the same material composition and colour as Jonite grates. They are mainly used when a drain encounters an irregular joint or to fill an odd end of a drain.

Light-duty (pedestrian-rated) models can be cut on-site by the installer, as shown below. Heavy-duty (vehicular-rated) models must be factory fabricated according to templates or full-scale CAD drawings provided by the installer.

1 LIGHT-DUTY GRATE TILES™

Light-Duty Grate Tiles™ are not reinforced and can be easily cut on-site with a circular saw. The shape and dimension required can be easily traced and cut on the Grate Tile™ as desired. It is important to note that the minimum length of the Grate Tile™ being supported must be at least 50mm.

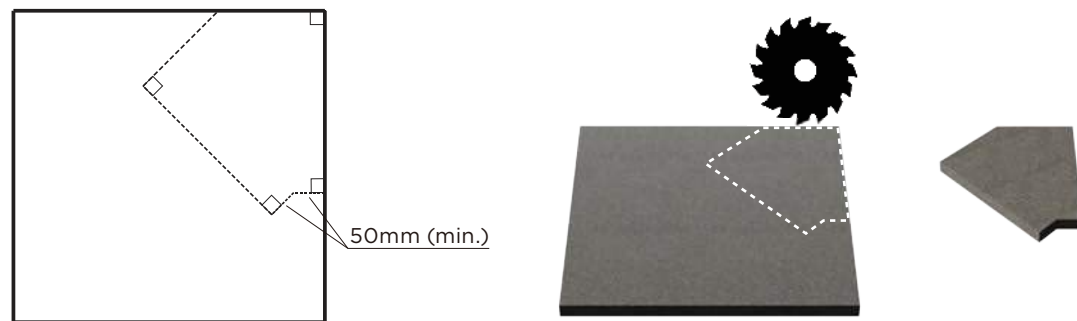

IMPORTANT: Supported length of the Grate Tile™ must be at least 50mm

1 Trace the desired shape and dimension & cut accordingly with a circular saw.

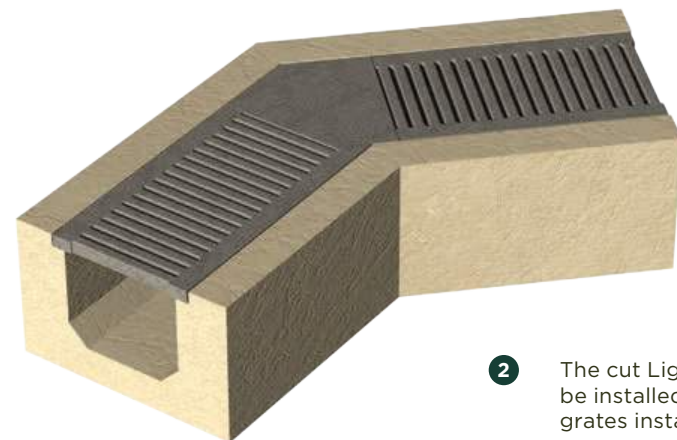

2 The cut Light-Duty Grate Tile™ can be installed together with the trench grates installation.

2 HEAVY-DUTY GRATE TILES™

Heavy-Duty Grate Tiles™ cannot be cut on-site due to their thick heavy reinforcements within. The shape and dimension required must be accurately traced onto a piece of cardboard or plywood. Alternatively, the installer can determine them onto a full-scale CAD drawing. The shape and reinforcements of the Grate Tiles™ will then be fabricated according to the templates or drawings provided.

1 Trace the desired shape and dimension accurately on to a wooden template or full-scale drawing.

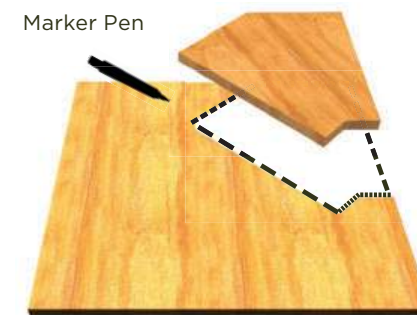
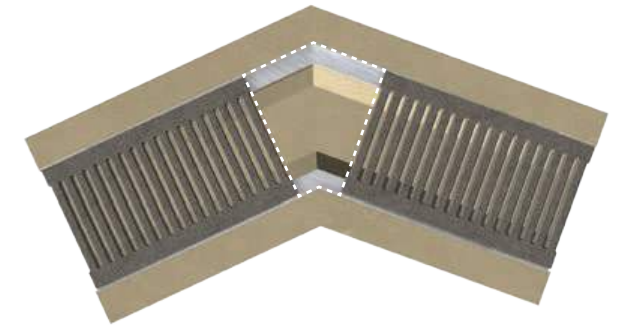

2 Send cut templates or drawings to Jonite for fabrication.

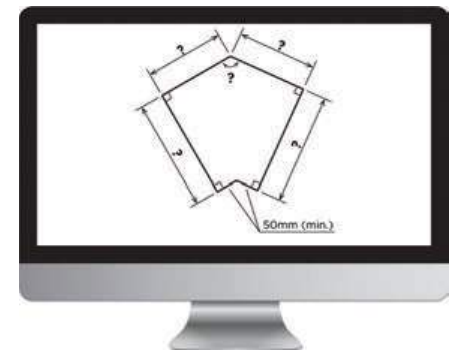

3 The cut Heavy-Duty Grate Tile™ should only be installed after the trench grates installation.

